

# Constant Current Dimmable Driver

- The housing is made from V0 flame retardant PC materials from COVESTRO.
- Small size and light weight. Wide range of applicable lamps.
- Class 2 LED driver, Safety Extra Low Voltage (SELV).
- Innovative thermal management technology intelligently protects the life of the LED driver.
- Overheat, overload, short circuit protection and automatic recovery.
- Up to 50,000-hour life time.
- 5-year warranty (AiSHi capacitor).



The certification icon represents on-going certification applications only, and final certification qualification is subject to actual products.



Model	Output Current	Input Current	Input Power	Output Power Range	PF	Typical Efficiency	Output Voltage	No load Voltage
S-530-C42W300-1050CG-6X-DALI	300mA	0.07A	14.68W	3.00-12.60W	0.86	85.8%	10-42V	59V
	350mA	0.08A	16.99W	3.50-14.70W	0.87	86.5%	10-42V	59V
	400mA	0.09A	19.31W	4.00-16.80W	0.88	87.0%	10-42V	59V
	450mA	0.13A	21.60W	4.50-18.90W	0.89	87.5%	10-42V	59V
	500mA	0.15A	23.91W	5.00-21.00W	0.90	87.8%	10-42V	59V
	550mA	0.16A	26.25W	5.50-23.10W	0.91	88.0%	10-42V	59V
	600mA	0.17A	28.63W	6.00-25.20W	0.92	88.0%	10-42V	59V
	650mA	0.18A	31.02W	6.50-27.30W	0.93	88.0%	10-42V	59V
	700mA	0.19A	33.41W	7.00-29.40W	0.94	88.0%	10-42V	59V
	750mA	0.20A	35.79W	7.50-31.50W	0.94	88.0%	10-42V	59V
	800mA	0.20A	38.18W	8.00-33.60W	0.95	88.0%	10-42V	59V
	850mA	0.21A	38.63W	8.50-34.00W	0.95	88.0%	10-40V	59V
	900mA	0.22A	40.90W	9.00-36.00W	0.96	88.0%	10-40V	59V
	950mA	0.23A	43.18W	9.50-38.00W	0.96	88.0%	10-40V	59V
	1000mA	0.24A	45.45W	10.00-40.00W	0.97	88.0%	10-40V	59V
1050mA	0.24A	47.72W	10.50-42.00W	0.97	88.0%	10-40V	59V	

\* Test result @230V, 50Hz, Full Load

## Parameters

Category	Item	Technical Norm
Features	Output Type	Constant Current
	Output Features	Isolation
	IP Grade	IP20
	Insulation Class	Class II Class (compatible Class I)
	Rated Input Voltage	220-240VAC
	Range of Input Voltage	198-264VAC
	Range of DC Input Voltage	180-280VDC
	Frequency	50/60Hz
	Overvoltage protection	2h@380VAC, 48h@320VAC
	Input Current	≤0.24A (230VAC, full load)
	Input Power	≤47.72W (230VAC, full load)

<b>Input</b>	Power Factor	≥0.97	(230VAC, full load)
	THD	≤15%	(230VAC, full load)
	Standby Power Consumption	≤0.45W	@230VAC (DIM to off)
	Inrush Current	≤18A/2.8us	(230VAC, full load)
	Connected quantity of 10A Breaker Connected quantity of 13A Breaker Connected quantity of 16A Breaker Connected quantity of 20A Breaker	11pcs/type A ;17pcs/type B ; 28pcs/type C @ 230Vac 14pcs/type A ;22pcs/type B ; 36pcs/type C @ 230Vac 18pcs/type A;27pcs/type B ; 44pcs/type C @ 230Vac 22pcs/type A;33pcs/type B ; 55pcs/type C @ 230Vac	
<b>Output</b>	Output Voltage Range	10-42VDC@300-800mA ; 10-40VDC@850-1050mA	
	No-load Voltage	59VDC Max.	
	Output Current	300mA-1050mA (Max.output) , Factory set current of 300mA	
	Max. Output Power	42W	
	Efficiency	≥88%	(230VAC, full load)
	Output LF current ripple (< 120 Hz)	±3%	(Imax-Imin) / (Imax+Imin)
	Current Accuracy	±5%	
	Starting Time (AC mode)	≤0.8S	(230VAC, full load,by DALI system)
	PstLM	≤1	
	SVM	≤0.4	
<b>Control Method</b>	Secondary PUSH dimming	Secondary PUSH dimming (Max. lead wire length:20m,same port of DALI)	
	DALI function	DALI dimming (Max. lead wire length:300m) logarithm or linear dimming curve selectable	
	Dimming range	DALI dimming: 1%-100%	
	PUSH-button	Max parallel connections qty for Push-dim 15	
<b>Protection</b>	Short Circuit Protection	Auto Recovery	
	Overload Protection	Auto Recovery (not be hot swap)	
	No-load Protection	Auto Recovery	
	Insulation voltage	3000V 5mA 60S between P-S	
	Insulation resistance	>100M ohm @ 500VDC	
	Leakage current	< 700μA, I/P to O/P or I/P @230V input	
<b>Environment</b>	Ta/Operation Temperature	-25....+35 C	
	Ts/Storage Temperature	-25....+75 C	
	Tc/Enclosure Temperature	75 C	
	Humidity	10%....90%RH	
	Atmosphere pressure	86-108KPa	
<b>Construction</b>	Connection Method	Push-in Terminal	
	Installation	Independent	
	SEC Wire preparation	0.5-1.5 <sup>□</sup>	
	Dimension	217.8*31.1*42.2mm (L*W*H)	
<b>Standards</b>	Certification	CE	
	Safety Standards	EN61347-1:2015/A1:2021;EN61347-2-13:2014/A1:2017;EN62384:2006/A1:2009;	
	DALI performance	EN 62386-101 (DALI-2),EN 62386-102 (DALI-2) EN 62386-207 (DALI-2, including part 251, 252, 253)	
	Performance	EN 62384	
	Surge	L/N-Ground:2kV; L-N:1kV	
<b>Others</b>	RoHs	complied to 2011/65/EU	
	Life Time	50000h	Tc=75 C
		75000h	Tc=70 C
		100000h	Tc=65 C
	Warranty	5years , F.R. < 10000ppm	

**Remark:**

- 1.All Parameters, if not specified, are measured at 230VAC/50Hz and 25 °C ambient temperature.
- 2.LED Driver is a component of the luminaires, Luminaires and wire layout will affect the EMC, please check the EMC with end products again.
- 3.Please make sure Tc under Lifetime condition when long term operate under DC input.
- 4.DC emergency (DCemDim):Default 15%, EOFx range = 1 .. 100% (EOFx = DCemDIM level).
- 5.During the PUSH DIM test,the number of parallel connections must be less than 15PCS.

Distance	15m	30m	50m
Cable selection	0.5mm <sup>2</sup>	0.75mm <sup>2</sup>	1.0mm <sup>2</sup>

## Output Current Setting

Output Current	1	2	3	4
300mA	-	-	-	-
350mA	-	-	-	ON
400mA	-	-	ON	-
450mA	-	-	ON	ON
500mA	-	ON	-	-
550mA	-	ON	-	ON
600mA	-	ON	ON	-
650mA	-	ON	ON	ON
700mA	ON	-	-	-
750mA	ON	-	-	ON
800mA	ON	-	ON	-
850mA	ON	-	ON	ON
900mA	ON	ON	-	-
950mA	ON	ON	-	ON
1000mA	ON	ON	ON	-
1050mA	ON	ON	ON	ON

## Label

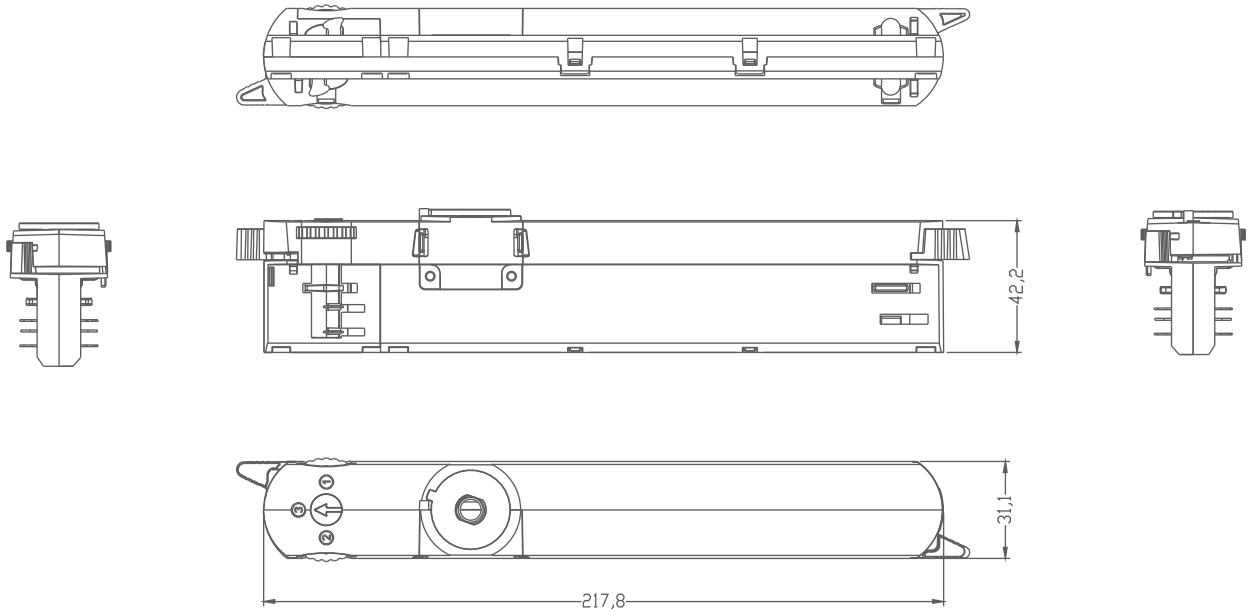
BLACK (RAL9011)/WHITE (RAL9010)/GRAY (RAL7040)

Pout [w]	Iout [mA]	λ	1	2	3	4	Pout [w]	Iout [mA]	λ	1	2	3	4
12.6	300	0.86C	-	-	-	-	29.4	700	0.94C	ON	-	-	-
14.7	350	0.87C	-	-	-	ON	31.5	750	0.95	ON	-	ON	-
16.8	400	0.88C	-	-	ON	-	33.6	800	0.96	ON	-	ON	-
18.9	450	0.89C	-	-	ON	ON	34.0	850	0.97	ON	ON	-	-
21.0	500	0.90C	-	ON	-	-	36.0	900	0.97	ON	ON	-	-
23.1	550	0.91C	-	ON	-	ON	38.0	950	0.97	ON	ON	-	-
25.2	600	0.92C	-	ON	ON	-	40.0	1000	0.97	ON	ON	-	-
27.3	650	0.93C	-	ON	ON	ON	42.0	1050	0.97	ON	ON	ON	-

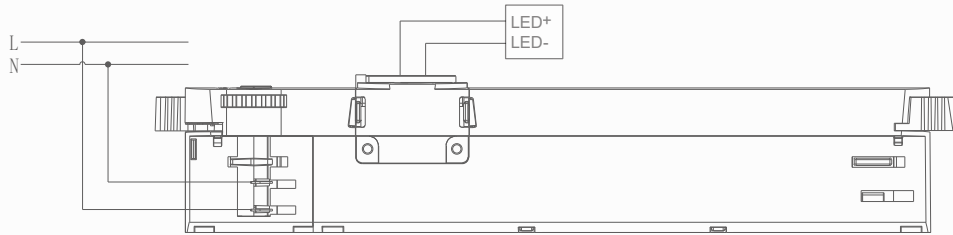
LED Dimmable Driver  
 S-530-C42W300-050CG-6X DALI  
 For LED modules only  
 Constant Current Lighting track adaptors  
 PRI:220-240VAC 50/60Hz Max. 0.24A  
 SEC:300-800mA 10-42VDC  
 850-1050mA 10-40VDC  
 U-OUT:59VDC Max. 42W  
 tc:75°C ta:35°C

Wiring diagram showing DALI control lines (DA+, DA-, N, L) and a 4-pin terminal block (1, 2, 3, 4) with an OFF position.

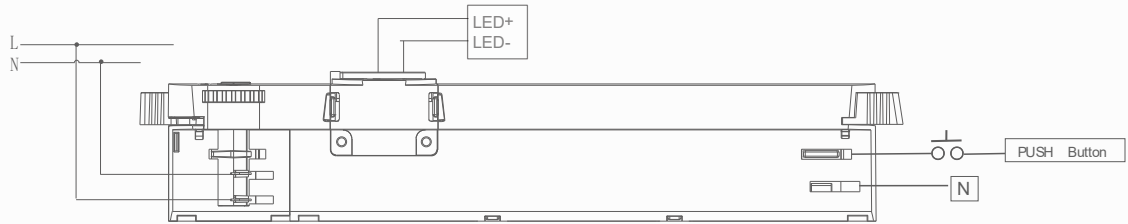
**Dimension**



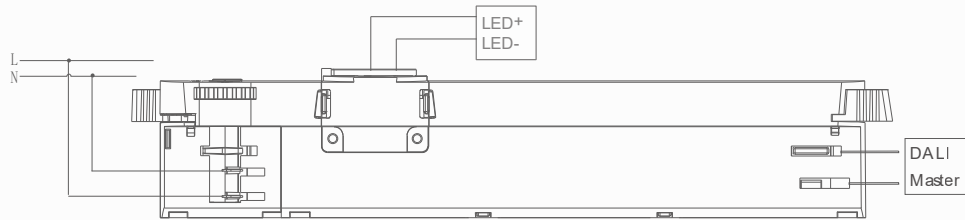
**Wiring Diagram**



**Fig.A: PushDimming**

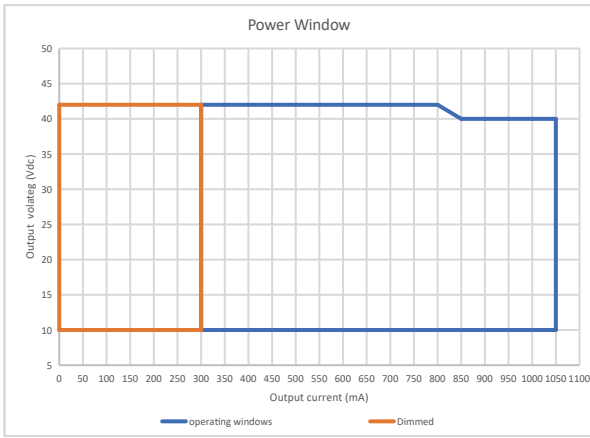


**Fig. B: DALI Dimming**

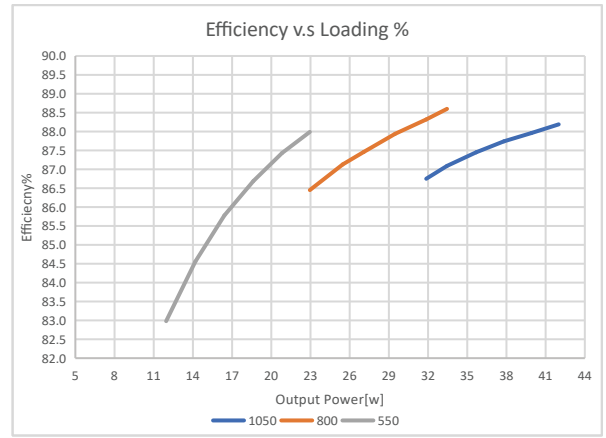


## Electrical values

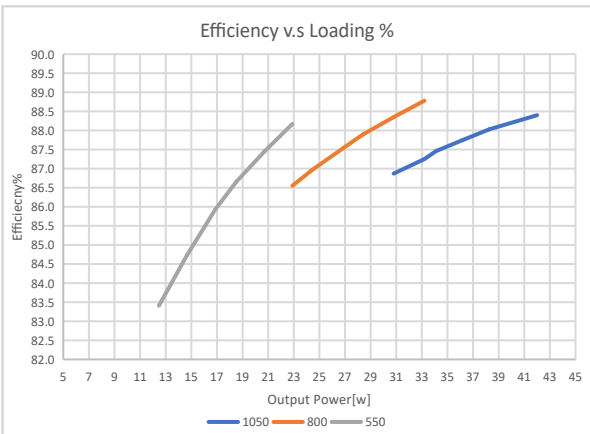
### 1. Operating power windows



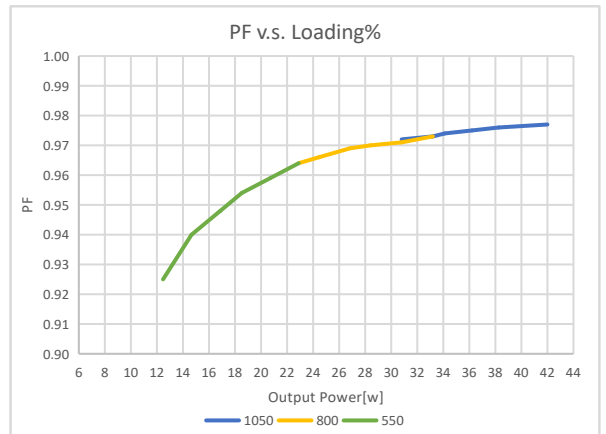
### 2. Efficiency v.s. Load



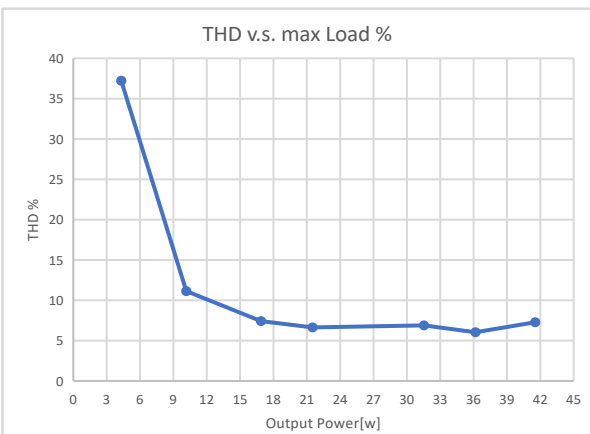
### 2. Efficiency v.s. Load



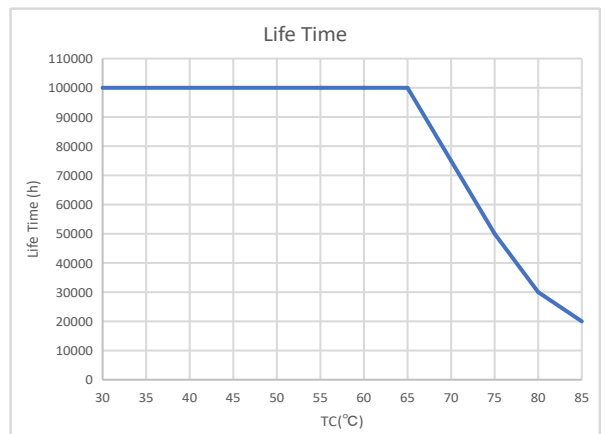
### 3. PF v.s. Load



### 4. THD v.s. Load



### 5. Life time



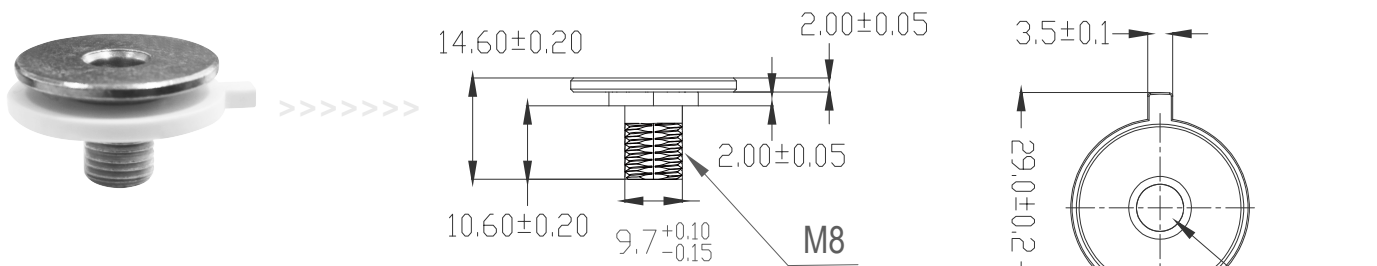
**Lamp Screw Type**

- Optional threaded sleeve for luminaire mounting
- Suitable for M10x1x8 threaded nut
- Additional mounting equipment, e.g. M10x1x12
- aluminium, black, white
- further on request

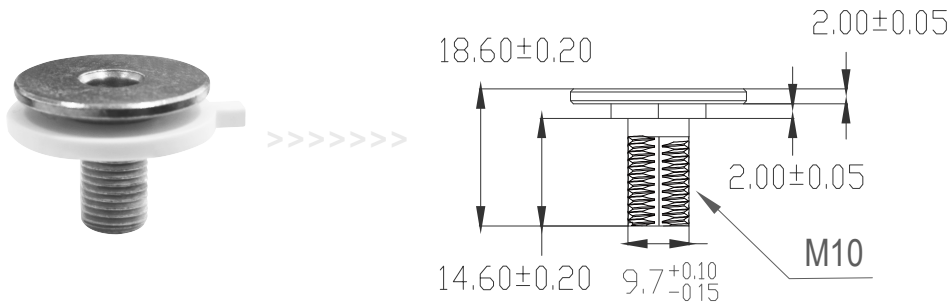
Ordering data 1

Type	Colour	Qty/ctn	Weight/pcs
M10x1x8	White	2500	9.6g
	Black	2500	9.6g
	Grey	2500	9.6g
M10x1x12	White	2500	10.0g
	Black	2500	10.0g
	Grey	2500	10.0g

M10X1X8 (White)



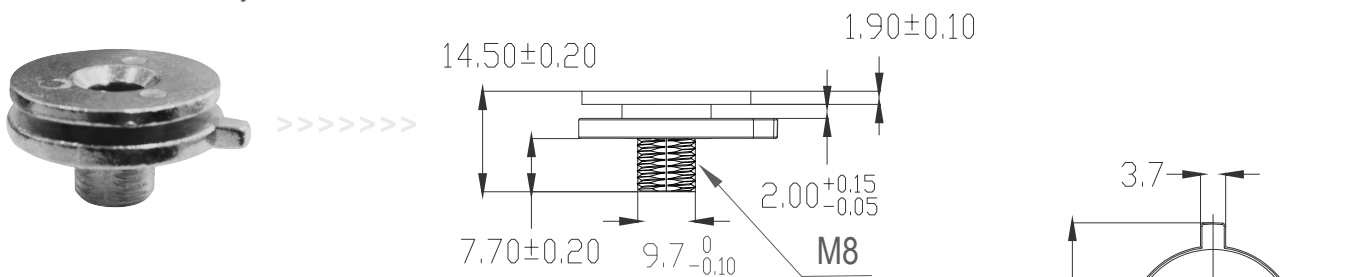
M10X1X12 (White)



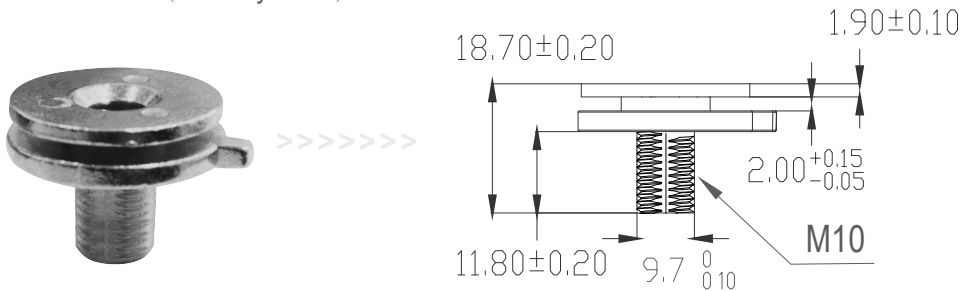
## Ordering data 2

Type	Colour	Qty/ctn	Weight/pcs
M10x1x8	White	2500	16.0g
	Black	2500	16.0g
	Primary color	2500	16.0g
M10x1x12	White	2500	16.9g
	Black	2500	16.9g
	Primary color	2500	16.9g

M10X1X8 (Primary color)



M10X1X12 (Primary color)



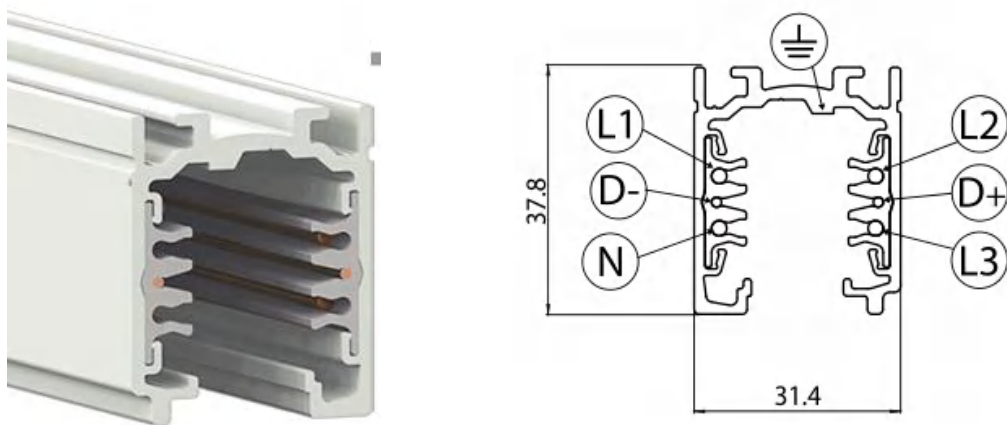
### Suitable for following tracks

Serial number	Brand	Track model	Serial number
1	Global	XTS 4&XTSF 4	3P
2	Stucchi	9000XX Series	3P
3	Eutrac	2510x	3P
4	Unipro	T32B	3P
5	Lvela	7501	3P

#### Remark:

- 1.The model name is XTS 4 and XTSE 4 tracks, and its brand is Global.
- 2.The model name used is the 9000XX track,and its brand is Stucchi.The“XX in the model name represents: it represents a different color.
3. The model name is 2510x tracks, and its brand is Eutrac.The“x”in the model name represents: it represents a different color(x=1white;x=2 black;x=3silverx=8 grey).
4. The model name is T32B tracksand its brand is Unipro.
5. The model name is 7501 tracks, and its brand is lvela.

### Phase track light rail specification:



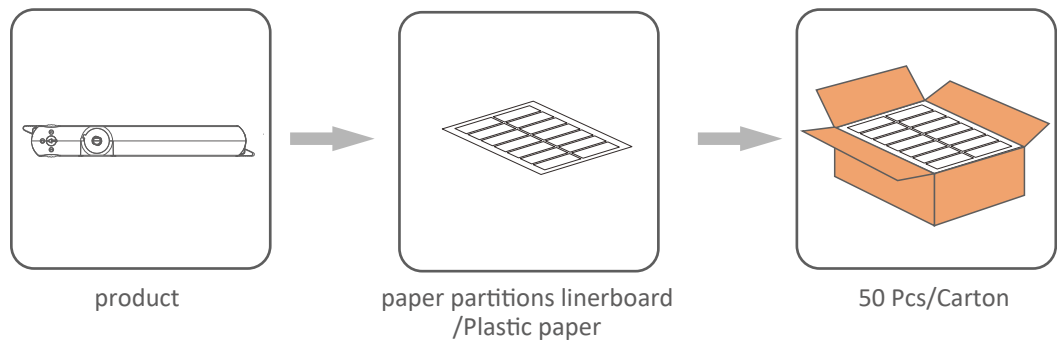


Lighting track adapter and rail system installation diagram:



The adaptor shall be given that the use is limited to the track system specified.

Packing information



Model	Carton L*W*H(mm)	Pcs/- Carton	Net weight/ Pcs(kg)	Net weight/ Carton(kg)	Cross weight/- Carton(kg)
S-530-C42W300-1050CG -6X DALI	395*295*125	50	T.B.D	T.B.D	T.B.D

## Wiring instructions

- All connections must be kept as short as possible to ensure good EMI behaviour
- Mains leads should be kept apart from LED Driver and other leads(ideally 5-10 cm distance)
- Advice the maximum length of output wires is 3m
- Secondary switching is not permitted(Except for constant voltage)
- Incorrect wiring can damage LED modules.
- The wiring must be protected against short circuits to earth(sharp edged metals parts,metal cable clips, louver, etc.)

## Push Dim :

### 1.On / off:

Short push (120ms-600ms) on the switch,Stepless dimming: long push (> 0.6sec) on the switch.

### 2.Power-on memory function

When the LED driver is powered on, it will restore the memory before the LED driver is powered off.

(brightness remembers the brightness after the last dimming is stable, and the brightness during dimming is not memorized)

### 3.Light on/off

If the light is on, the light will be off after a short press. If the light is off, the light will be on after a short press.

The time range of short press is 120-600mS.

### 4.PUSH Dimming

Press and hold the push switch for a long time, the light will enter the dimming state, if the previous time is dimming, it will automatically turn to dimming the next time.After releasing the reset button, the dimming stops and the current illuminance is maintained. The dimming range is 1%-100%. The default is to dim when the power is first long-press. If the brightness of the power-on is the maximum brightness, the first long-press is to dim. (Long press 0.6-3S to start dimming.)

5.Forced synchronization

Long press for 10 seconds to turn on all the lights and turn on the same brightness (50%), and continue to quickly short press will not change. After a short period of time without short press operation, the module exits the synchronization mode, and the short press restores the switch function.

6.PUSH Dimming rate

Long press the push switch 10S to switch the dimming rate to 3S, Long press the push switch 20S to switch the dimming rate to 6S.

**REVISION HISTORY**

Date	Revision	Remark